



C-RACER
www.c-racer.com

INSTRUCTION

Page 1/2

Model	Product	Code
YAMAHA Tenere 700/T7	Front Fender (Street)	FFS-YT7

CONTENTS

1. 1pcs Plastic Fender
2. 2pcs Metal base
3. 2pcs screws M5X15 (a allen oval washer)
4. 2pcs sliding clips M5
5. 2pcs screws M6X15 (a allen-oval-washer)
6. 2pcs safety nuts M6
7. 2pcs washers 6X18
8. 1pcs screw M8X70 allen
9. 1pcs safety nut M8
10. 2 pcs washer 8X24
11. 2pcs foam tipe 2X10X100 (for package)

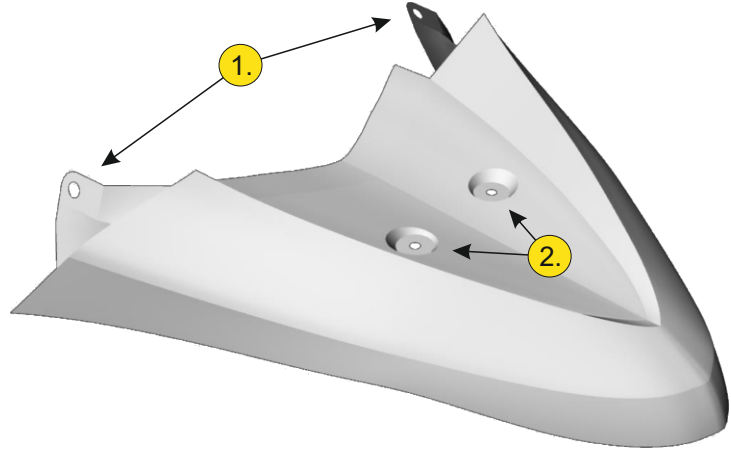

The inside of the fairing has a plastic part that extends to the bottom and is held by plastic clips (left photo). Remove the first upper clip and open the plastic to fit your hand. In the hole that fastenes the clip, put the sliding thread that you will find in the package, mount it well and return the plastic to its position. Store the clip.

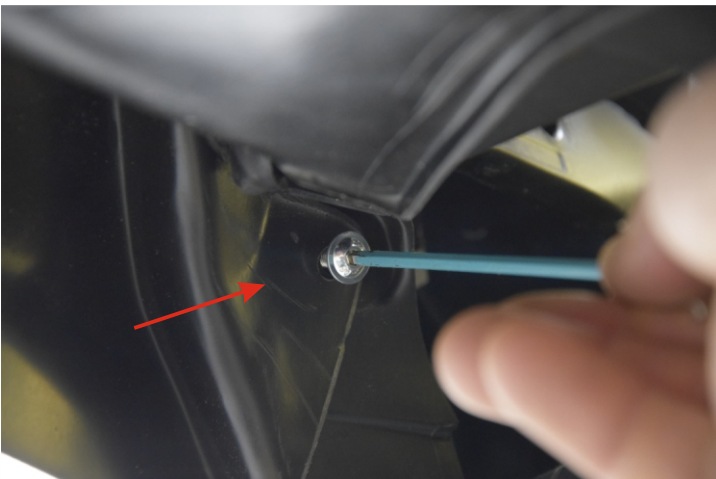

Remove the protective film on the back of the new fender and replace it. Screw the two small screws (M5X15) included in the package to the right and left of the fender on the inside as demonstrated in the photo. Just press the screws to hold the fender in place without tightening it properly.

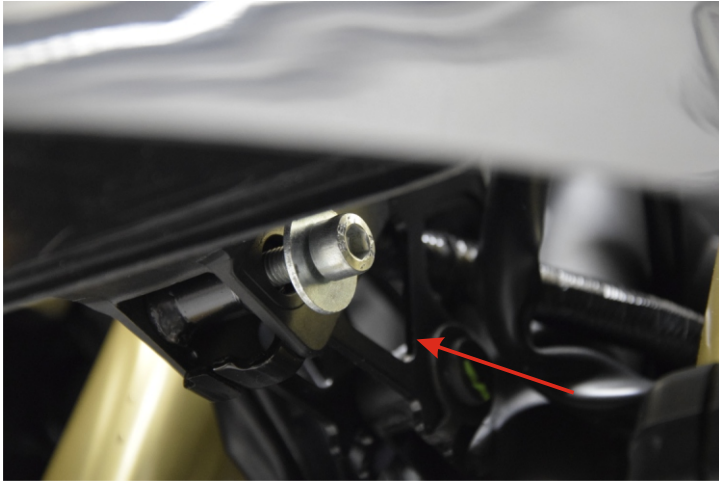

Remove only the bottom screw from the base that supports the lantern as shown in the photo. Store the screw and the clips, in case you want to restore the motorcycle to the original form.



Install the two metal bases on the package exactly as shown in the photo. This is an extra support for the fender. Tighten the screws (M6X15) first and then the center screw on the base of the lantern. Finally, tighten the two side screws that secure the ferrules. Pay special attention to the central screw being tight.



ΝΑ ΣΒΗΣΟΥΜΕ ΤΟ
ΜΟΤΟΚΙΝΗΣΙ

This will be your final result. Stay safe and enjoy the ride!

The product is for race use only

For any further information please do not hesitate to contact us: Tel.: +30 2108075387 Email: info@c-racer.com